



Project 1

**4'L x 2'W x 2'H**



Project 2

**7'L x 4'W x 4'H**

# Aquarium Design Group

Kessil

KSL-L-100402-  
Aquarium-220201A

# DESIGN REQUIREMENT- Project 1

Plant Type: **Hardscapes + low light plants**

Sunlight Intensity Equivalent: **200 fc**

Hours of Illumination per day: **12-14 hours**

Sunlight availability: **No**

Location: Gallery

Tank Dimensions: **4'L x 2'W x 2'H**

Interior Building Ceiling Height: **10'**

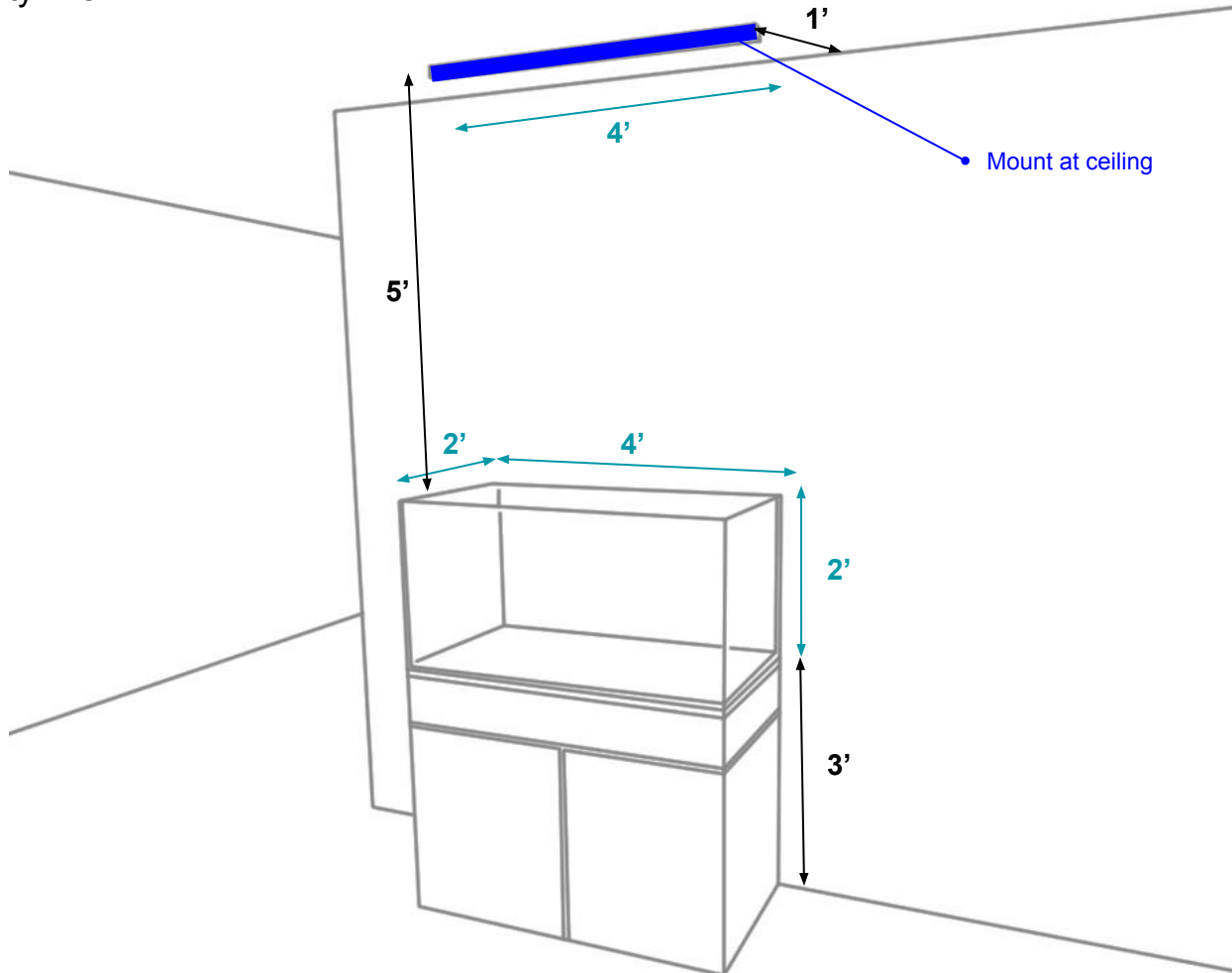

# LIGHTING LAYOUT

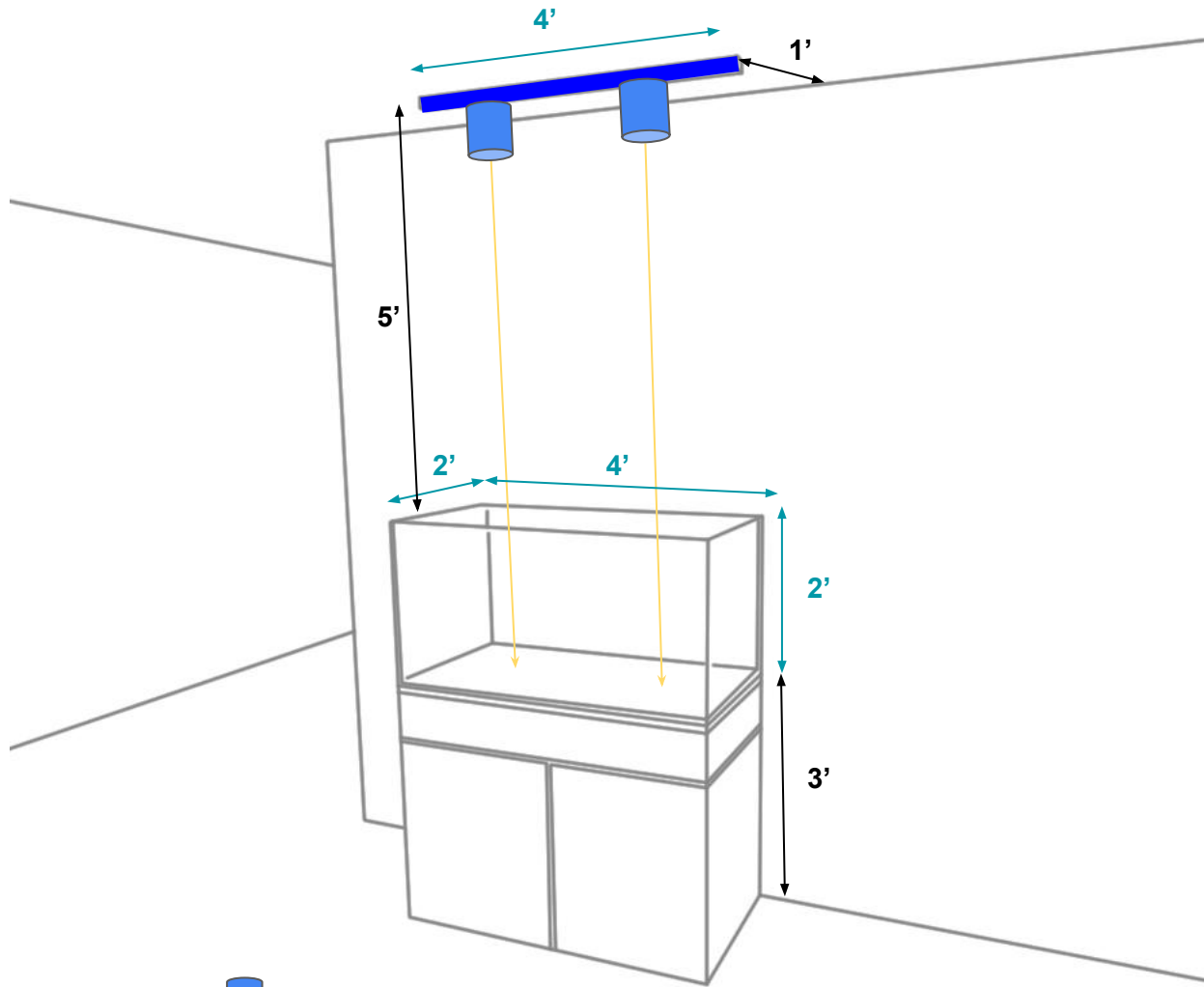

 W360N-AMZ

# HEAT MAP

## TOP VIEW

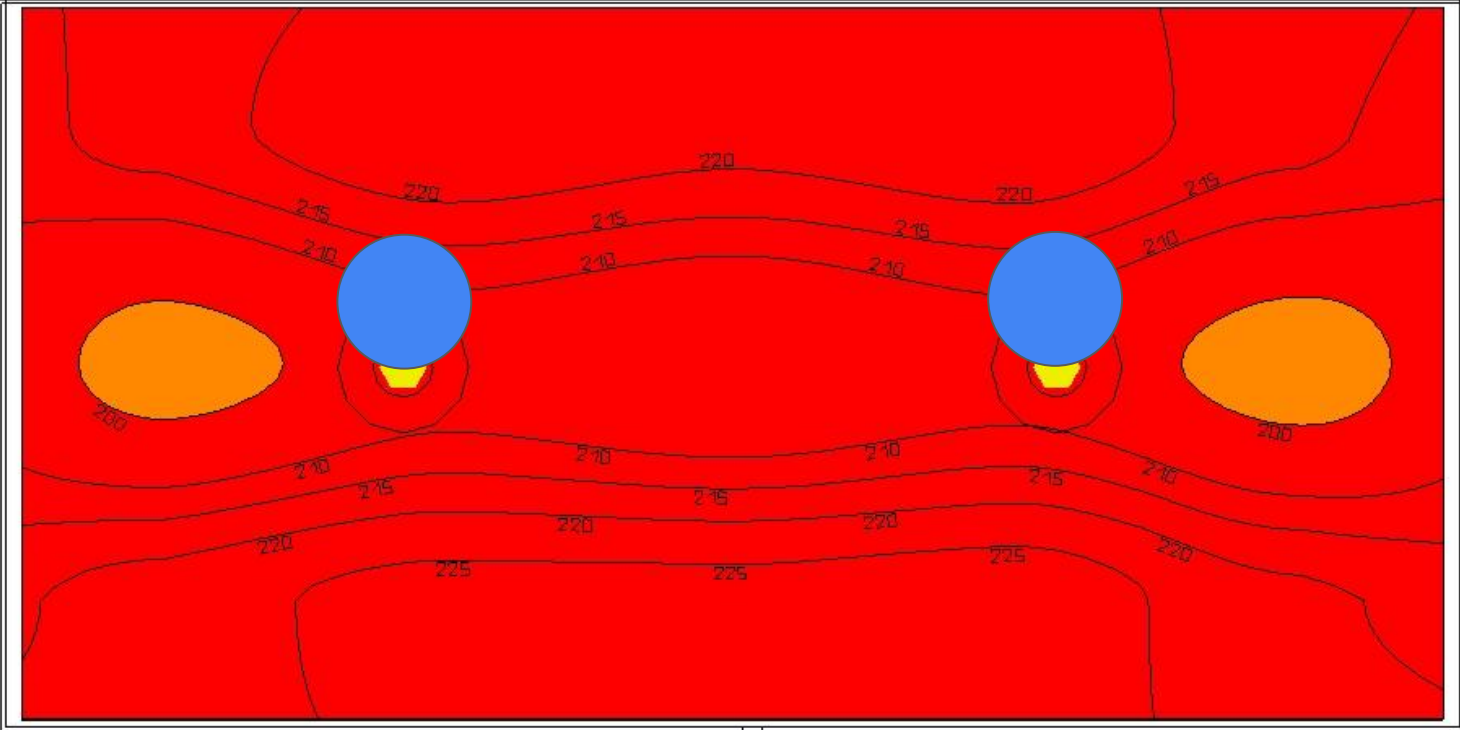

**Maximum footcandle: ~ 228 fc**

**Average footcandle: ~ 216 fc**

 W360N-AMZ (2x)

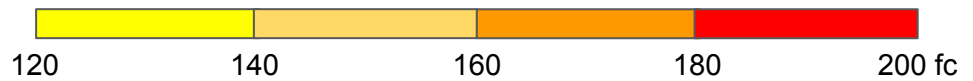

# PARTS LAYOUT

## TOP VIEW

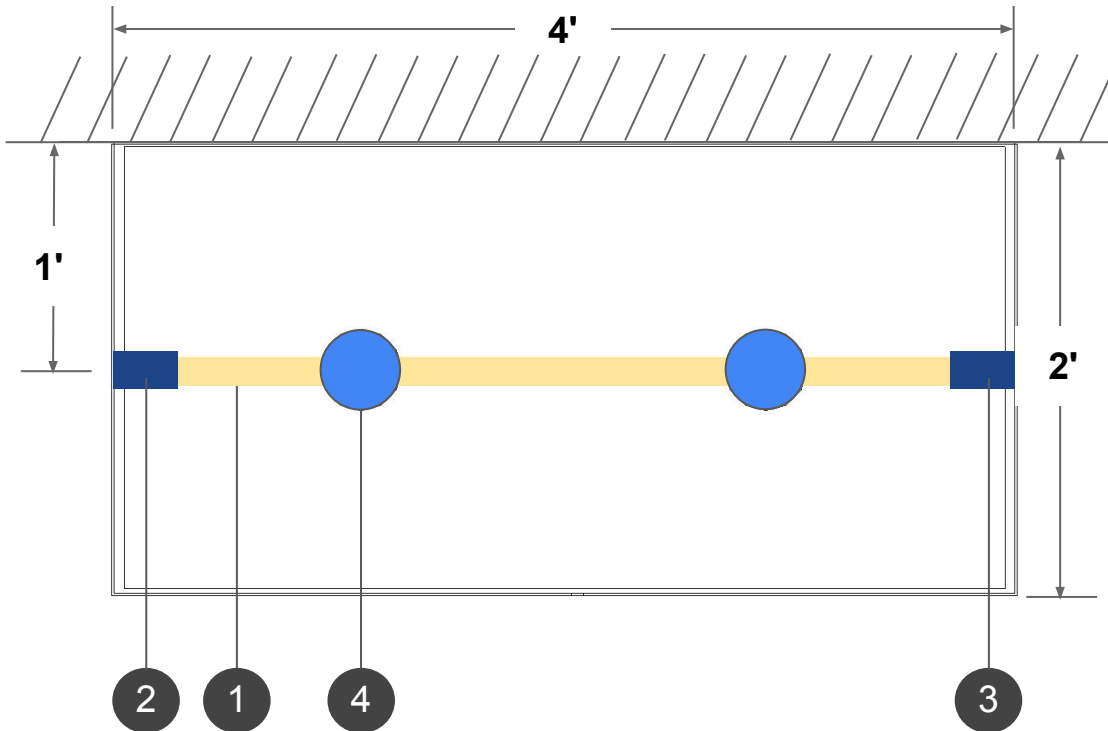

## Usage

Ceiling Height - 10'

Area Used - 4' X 2'

Electrical - 120V AC

- 1 4 ft TRACK (1x)
- 2 LIVE END - RIGHT (1x)
- 3 LIVE END - LEFT (1x)
- 4  W360N-AMZ (2x)

Max Power Consumption –  
80W x 2 units = 160W

# DESIGN REQUIREMENT - Project 2

Plant Type: **Hardscapes only**  
(minimal light preferred)

Sunlight Intensity Equivalent: **150 fc**  
Hours of Illumination per day: **12-14 hours**

Sunlight availability: **No**

Location: Gallery

Tank Dimensions: **7'L x 4'W x 4'H**

Interior Building Ceiling Height: **10'**

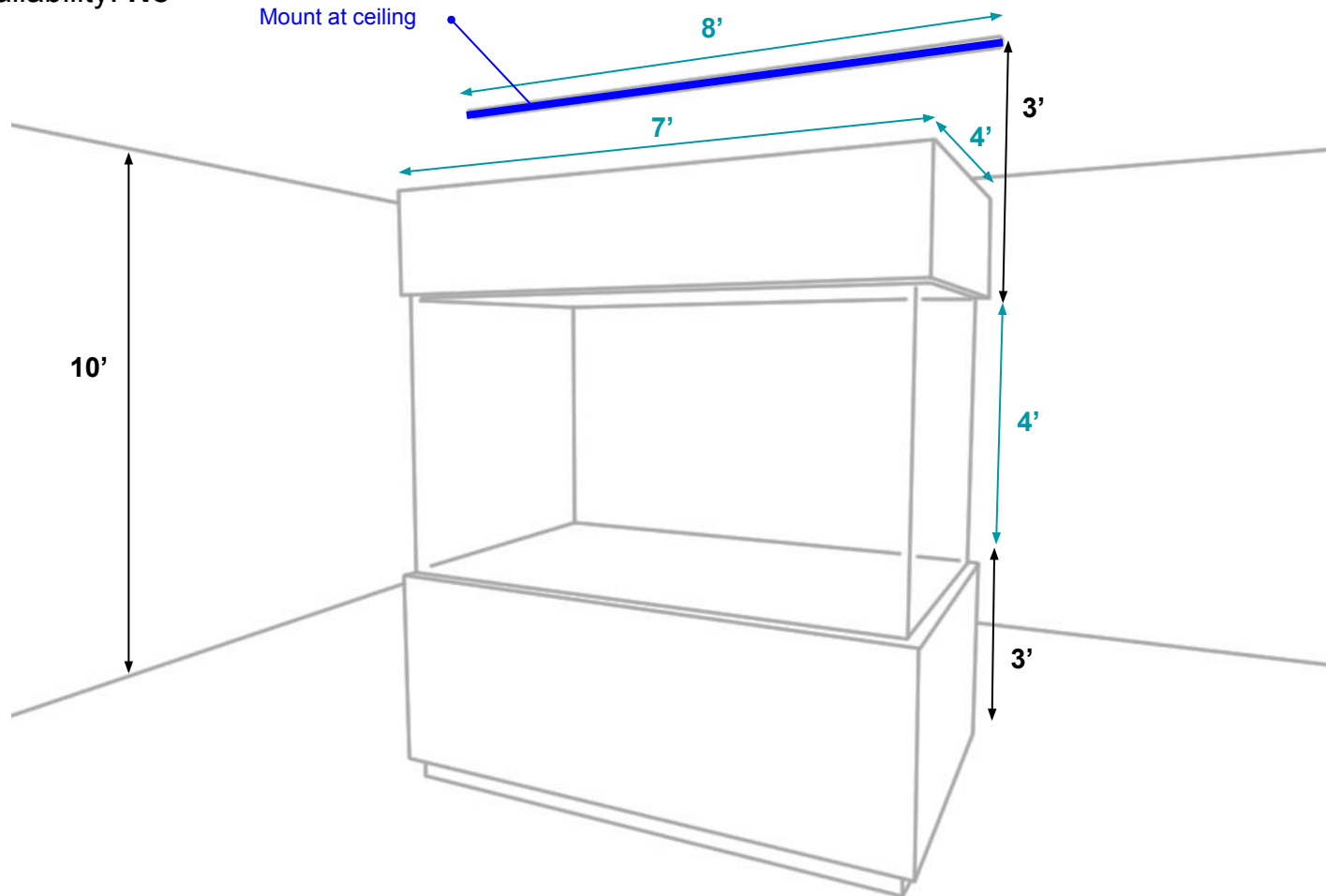

# LIGHTING LAYOUT

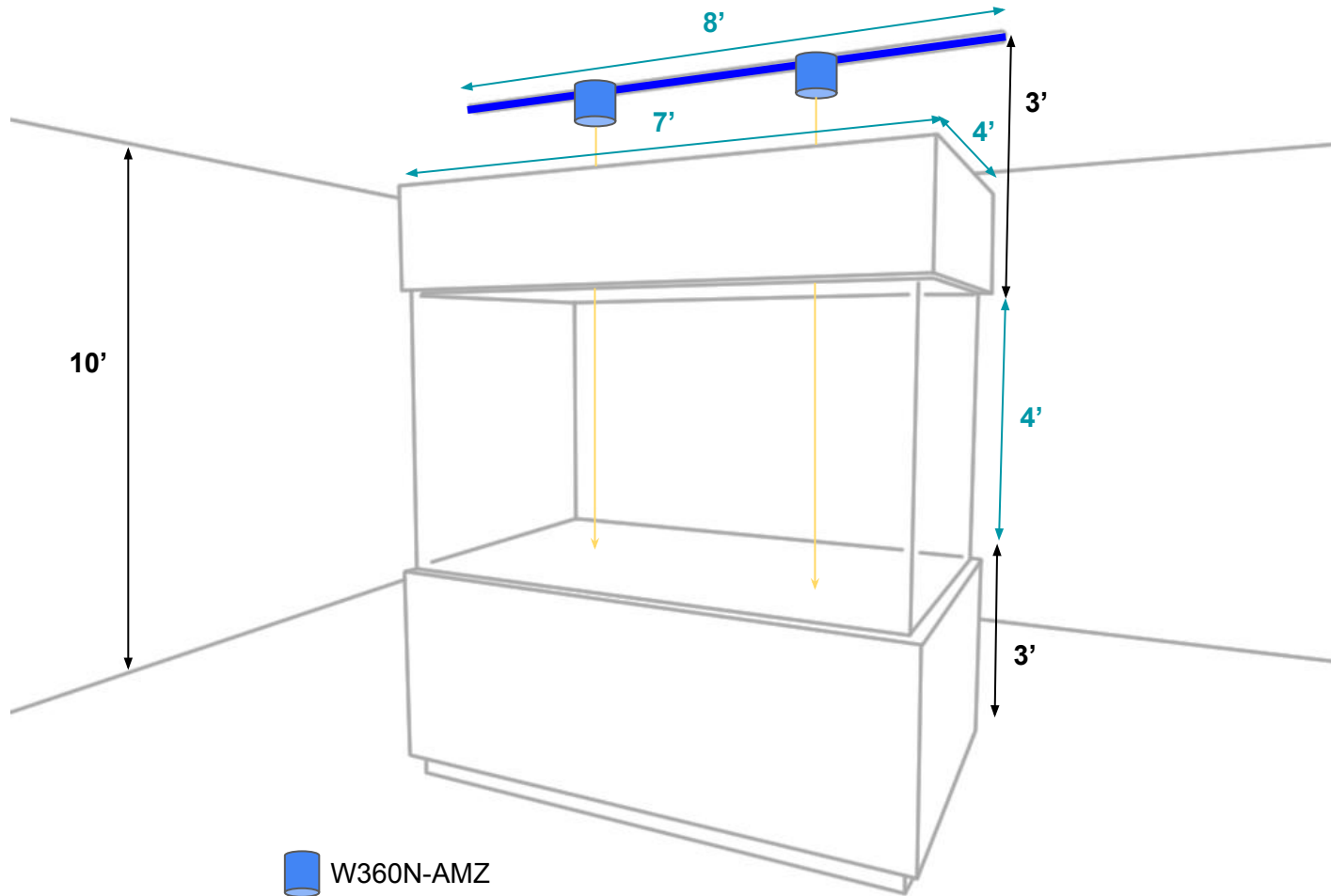

# HEAT MAP

## TOP VIEW

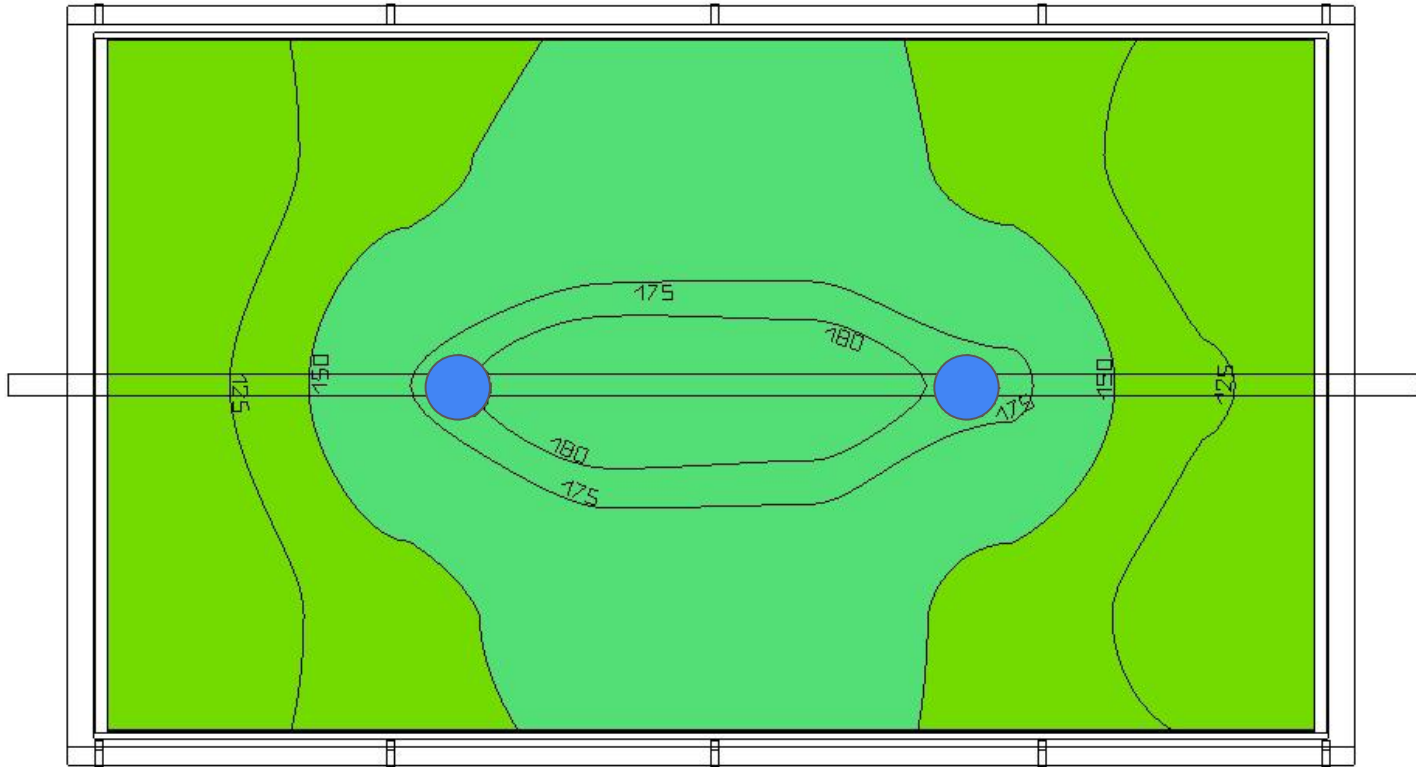

**Maximum footcandle: ~ 186 fc**

**Average footcandle: ~ 146 fc**

 W360N-AMZ (2x)

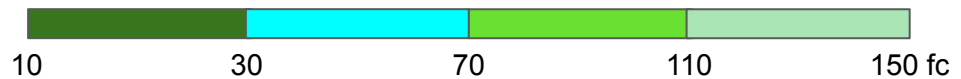



# KESSIL ADVANTAGES

- Patented LED Technology for Pendant fixtures
- LED aquarium lighting expertise since 2010
- Unrivalled natural shimmer
- Spectrum designed specifically to promote plant/coral growth
- Single point source with high intensity
- Added optics for delivering light to distance
- Compact size - minimizing fixture distraction from the aquarium

